



OUR TECHNOLOGY. FOR YOUR HEALTH.

MAXIMO[®]

*An Evolution in Sitting Comfort for
Medium and Heavy-Duty Tractors.*

**New
Seat Design**



GRAMMER



MAXIMUM SITTING COMFORT.



Farming is Getting More Professional. And so are our Seats.

Rapid restructuring of the agricultural sector and increasingly professional approaches have dramatically changed the nature of everyday farming work. This has prompted us to optimize the features and design of our proven Maximo® series. For professional applications, the Maximo® Evolution Active extends its lead in ergonomics and comfort with a suspension that boasts active electronic control. For our passive seats with pneumatic suspensions, we have set new standards by introducing the Dynamic Damping System™ in the Maximo® Evolution Dynamic and the Maximo® Dynamic. The Maximo® Professional also meets the need for greater comfort; it has a low-frequency suspension system as standard equipment. Among our seats with pneumatic suspension, the entry-level model Maximo® Comfort offers attractive price/performance – as does the Maximo® Basic in the group of models with mechanical suspension.

The Maximo® Models: Setting New Trends in Terms of Comfort.

All models of the Maximo® series naturally place top priority on comfort. Take the ergonomic shape of the tapered backrest, for instance, or the wide cushions and armrests – they maximize freedom of movement while preventing slipping and sliding. Every Maximo® can also be easily adjusted to turn it into a personal comfort seat for each user.

Another important requirement for feeling good in the driver's seat is a pleasant temperature. But with conventional air-conditioning, the driver perspires where his or her body contacts the seat. That is why the Maximo® Evolution Dynamic and Maximo® Evolution Active are equipped with active climate control. This system removes body moisture so the user will never again have to sit drenched in sweat. And on cold days, the integrated seat heating keeps you snug.



Everything Under Control: Design for Use!

To maximize operating convenience, GRAMMER developed its "Design for Use" philosophy: all control elements are designed and placed to let the user intuitively tell how they work.

The shape of each one alone tells you whether to pull, press or turn it. The controls are also positioned according to how often they are needed. This lets the user quickly make the required adjustments to optimally position the seat to meet his or her personal requirements.



Dynamic Damping System™

Suited for medium and heavy-duty tractors.

The Dynamic Damping System™ opens up a new dimension in seats with passive suspensions for large and mid-sized tractors. This newly developed system improves further on the proven low-frequency suspension, reducing low-frequency vibrations even more effectively. At the same time, it prevents the seat from striking the vertical stops when accelerating rapidly on uneven terrain. This not only significantly eases stresses and strains on the driver, but also sets new standards of passive suspension comfort, productivity and cost-effectiveness.



**Maximo®
Evolution Dynamic**



Maximo® Dynamic

AN EVOLUTION IN SUSPENSION COMFORT.



Low-Frequency Suspension

Suited for medium and heavy-duty tractors.

The vibration-optimized pneumatic suspension is ideal for heavy-duty vehicles with a low natural frequency. For example, the low-frequency suspension absorbs vertical vibrations and jolts to prevent the seat from bouncing in critical work situations. A positioning system also automatically sets the seat to the operator's weight.



Maximo® Comfort Plus



Maximo® Professional

Pneumatic Suspension

Suited for standard tractors.

It could hardly be easier to set the seat's height and adjust it to the driver's weight: simply by pressing a button! The convenient operation and comfort of the pneumatic suspension deliver a crucial advantage: the operator stays fit longer.



Maximo® Comfort



Maximo® Basic

Mechanical Suspension

Suited for standard tractors.

In the Maximo® Basic, the seat's height can be set to any of three positions via a ratcheting mechanism that securely locks it into place. It is also set precisely to the driver's weight by hand using a lever. The result: maximum suspension comfort in the seats with mechanical suspension.



EAC Suspension with 12V Power Supply.

For heavy-duty tractors. The EAC (electronic active control) suspension of the Maximo[®] Evolution Active minimizes the vibrations and jolts that drivers of large tractors are subjected to. This innovative new electronic system for active vertical suspension reliably reduces potentially health-endangering vibrations by 40 percent compared to proven low-frequency suspensions. High-intensity jolts are attenuated by up to 75 percent. The Maximo[®] Evolution Active is a plug & play solution, making it easy to install.

The result: a substantial gain in suspension comfort for exemplary protection from health hazards. It also complies with the EU directive on whole-body vibration (2002/44/EC), which has already been enacted as national law.

Integrated Backrest Extension

In 13 steps from 475 to 645 mm to precisely mold the seat to the user's body.

Active Climate System, incl. Heating

For a pleasant seat climate at all times.

Foldable Armrests

Height- and angle-adjustable.

VISIONARY KNOW-HOW

Variable Seat Cushion Depth

Adjustable in 5 steps to optimally support thighs of different lengths.

Flexible Seat Cushion Angle

Adjustable in 4 steps to reduce pressure on the backs of the knees.

210 mm Fore/Aft Adjustment

For easy positioning of the seat in the vehicle.

Fore/Aft Isolator

This feature minimizes vibrations when traveling fast, when pulling attachments or trailers, and when working on rough terrain.

Suspension with Electronic Active Control (EAC)

Featuring fully automatic weight adjustment.





Document Box

Tapered Backrest

For greater freedom of movement.

Pneumatic Lumbar Support

Adjusts quickly and precisely to the driver's back to provide ideal support.

Switch for Active Climate System

(Incl. Heating)

MAXIMO®

Evolution

active

Adjustable Backrest Angle

Swivel

Pivots through 20° to facilitate getting in and out and checking equipment attached in back.

Lateral Suspension

No more sideways pitching!

80 mm Height Adjustment

The ideal sitting position for every body size.

Adjustable Shock Absorber

For adjusting to different usage conditions.

The model shown may deviate from the standard configuration





**Maximo®
Evolution
Active**

**Maximo®
Evolution
Dynamic**

**Maximo®
Dynamic**

**Maximo®
Professional**

**Maximo®
Comfort
Plus**

**Maximo®
Comfort**

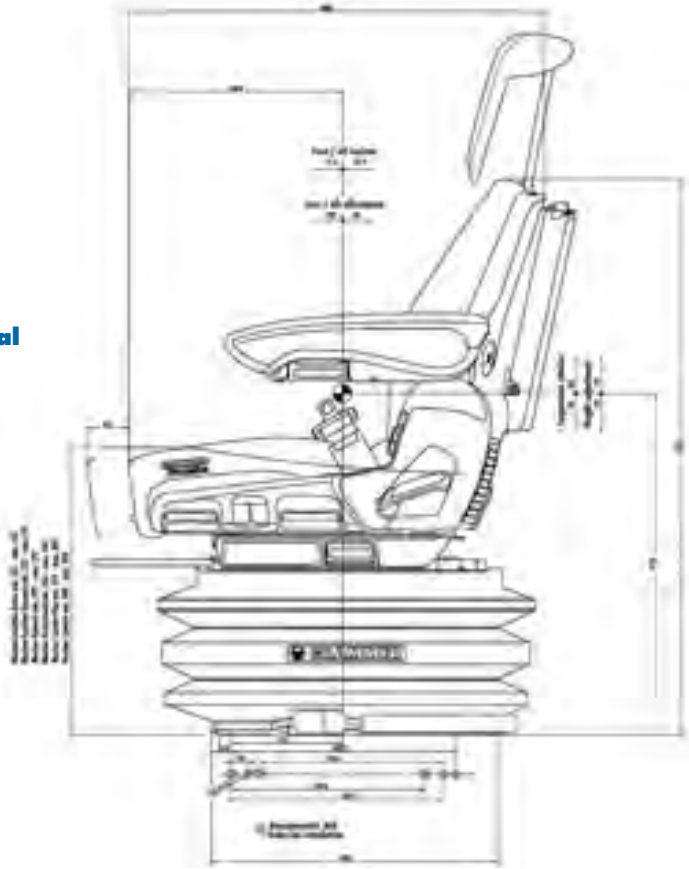

Air Suspension

SITTING COMFORT BUILT TO MEASURE.

Mechanical Suspension

**Maximo®
Basic**

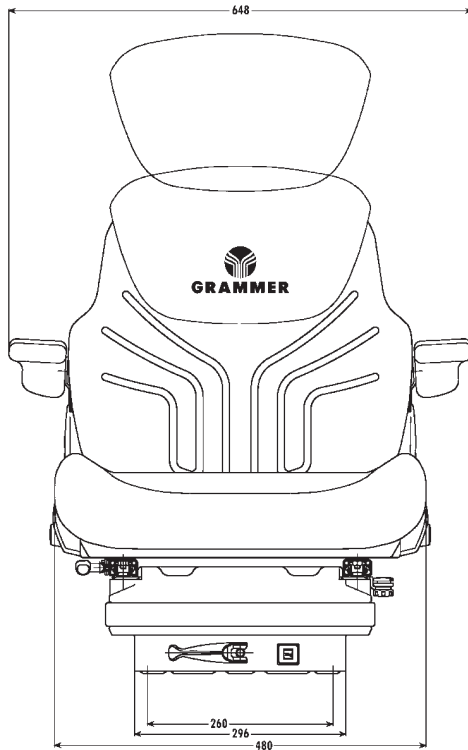

FRONT VIEW

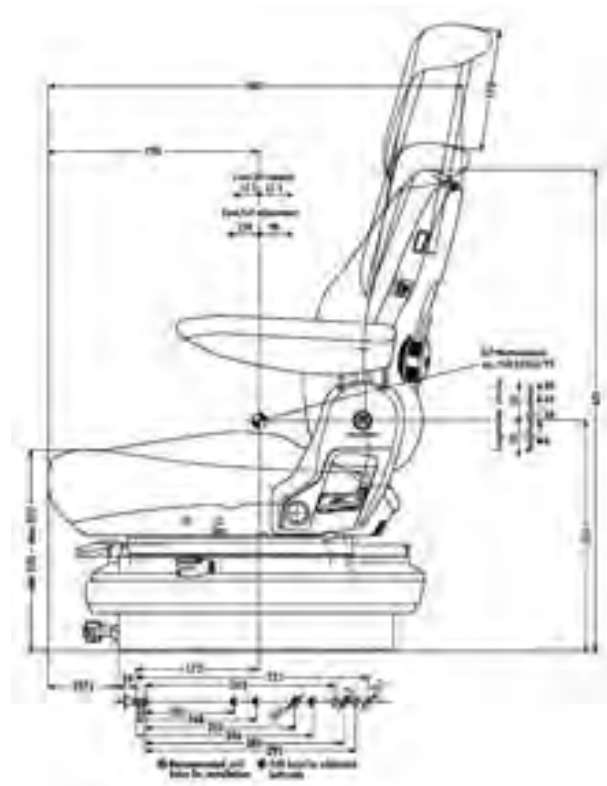

SIDE VIEW



**Maximo®
Professional**



**Maximo®
Comfort Plus**



**Maximo®
Comfort**



**Maximo®
Basic**



**Maximo®
Evolution Active**
Article no. Fendt: 1297511



**Maximo®
Evolution Dynamic**
Article no. Fendt: 1288768
Article no. Same: 1288766



**Maximo®
Dynamic**

The models shown may differ from the standard configuration.

MANY MODELS WITH MANY BENEFITS IN COMMON.

FEATURES	Maximo® Evolution Active	Maximo® Evolution Dynamic	Maximo® Dynamic	Maximo® Professional	Maximo® Comfort Plus	Maximo® Comfort	Maximo® Basic
Article no. fabric	1288762	1288764	1288545	1288547	1288546	1288539	1288528
Article no. imitation leather					1234485	1201942	
Document box	●	●	●	○	○	○	
APS (Automatic positioning system)	●	●	●	●	●	●	
Armrests height-adjustable and foldable	●	●	●	●	●	●	●
65 mm x 270 mm						●	●
60 mm x 380 mm, adjustable angle				●	●		
80 mm x 380 mm, adjustable angle			●				
80 mm x 380 mm, adjustable angle, with fabric cover	●	●					
Shock absorber							
Automatic	●	●	●				
Adjustable				●			
Nonadjustable					●	●	●
Swivel 20°	●	●	●	●			
Suspension							
Mechanical suspension						●	
Air suspension with 12 V compressor	●	●	●	●	●	●	
Low-frequency suspension				●			
Dynamic Damping System™		●	●				
Electronic active controlled suspension	●						
Suspension stroke							
100 mm				●	●	●	●
120 mm	●	●	●				
Weight adjustment							
Manual						●	●
Automatic			●	●	●		
Active (electronic)	●	●					
Height adjustment							
60 mm, infinite (air-assisted)						●	
80 mm, infinite (air-assisted)	●	●	●	●	●		
80 mm, 4-step (mechanical)							●
Climate system							
Passiv							
Activ	●	●					
Fore/aft adjustment 210 mm	●	●	●	●	●	●	●
Fore/aft isolator	●	●	●	●	●	●	●
Lumbar support							
Pneumatic	●	●	●				
Mechanical				●	●	●	●
Adjustable backrest angle	●	●	●	●	●	●	●
Integrated backrest extension	●	●	●	●	●	○	○
Lateral suspension	●	●	●	○	○	○	○
Seat cushion width	550 mm	550 mm	550 mm	530 mm	530 mm	520 mm	480 mm
Seat heating	●	●	●	○	○	○	○
Adjustable seat cushion depth and angle	●	●	●	●	●		
Operator presence switch (OPS) 0/22 Ohm	●	●	○	○	○	○	○
OPTIONAL FEATURES							
Restraint system	○	○	○	○	○	○	○

● Standard features ○ Optional features

Important note: Before installing, the conditions (mounting, connection ratings) in each case must be checked. Subject to technical modifications.

GRAMMER offers state-of-the-art products for all mobile workplaces – from tractors, construction machines and forklift trucks all the way to trucks, buses and trains. Ergonomically designed, they set new standards of sitting comfort and operating convenience. Just ask us – we'll be happy to inform you.

