



# KAB // Seating

## AGRICULTURAL SEATING



**NEW  
FOR JULY  
2011**



[www.kabseating.com](http://www.kabseating.com)

enter the comfort zone





# KAB//Seating

The latest KAB Seating range of air and mechanical suspension seats are suitable for :

**Vineyard tractors**

**Small agricultural tractors**

**Medium agricultural tractors**

**Large agricultural tractors**

**Telescopic handlers**

**Combine harvesters**

**Ride on mowers**

**LB** LOW BACK    **MB** MEDIUM BACK

These suspension seats offer drivers improved comfort and protection from harmful vibrations in their working environment and they fit most popular agricultural vehicle brands.

The following comfort and safety options are also available:

- 20° left/right swivel device
- Seat Belts
- Armrests
- Backrest extensions
- Lumbar support
- Fore and aft isolators (800/100 series)
- Heating elements (12v,24v or 48v)
- Headrests
- OTR - One touch riser (800 Air)
- Height adjustment systems
- Seat sensor switch
- Fabric or PVC trims
- 12v or 24v compressors (800/100 Air)

As part of a revamp of the KAB Seating range for agriculture, we are pleased to introduce for July 2011, several new seating packages and features.

**For the 800 series, we introduce the Invictus Air 85/K6 which offers:**

- K-Series seat cushion length and tilt adjustment
- Electrically powered air lumbar support
- Air ventilation system for cooling and heating

**K1 and K6 uppers for 800/100 series suspension.**

**New Compact seat (in both air and mechanical versions) for ride on mowers and groundcare machines.**

These represent a significant range enhancement from KAB Seating



# AIR 85/E6



- Suspension Type:** Air 85 low frequency
- Upper Type:** E6 low back
- Belt Type:** 2" optional
- Suspension Stroke:** 175mm
- Height Adjust:** Vertical 75mm integral
- Weight Range:** 50 - 120kg
- Vehicle Categories:** EEC type approved classes I/II/III
- Air Control:** 12v integral compressor
- Special feature:** OTR one touch riser for immediate mid-stroke positioning

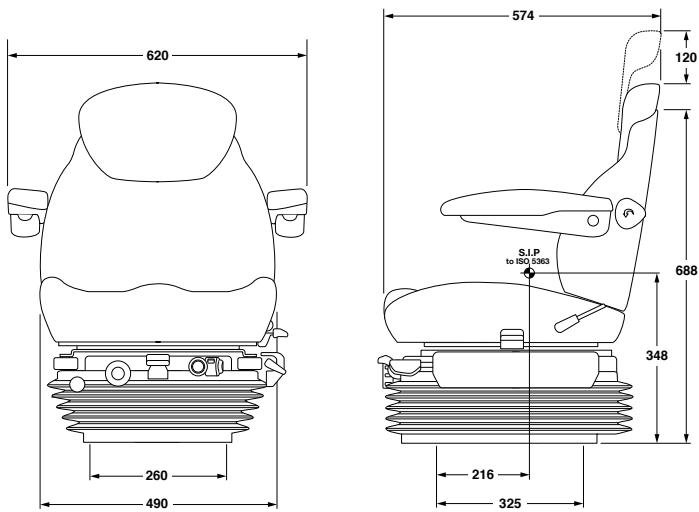

# AIR 85/E1



- Suspension Type:** Air 85 low frequency
- Upper Type:** E1 mid back
- Belt Type:** 2" optional
- Suspension Stroke:** 175mm
- Height Adjust:** Vertical 75mm integral
- Weight Range:** 50 - 120kg
- Vehicle Categories:** EEC type approved classes I/II/III
- Air Control:** 12v integral compressor
- Special feature:** OTR one touch riser for immediate mid-stroke positioning

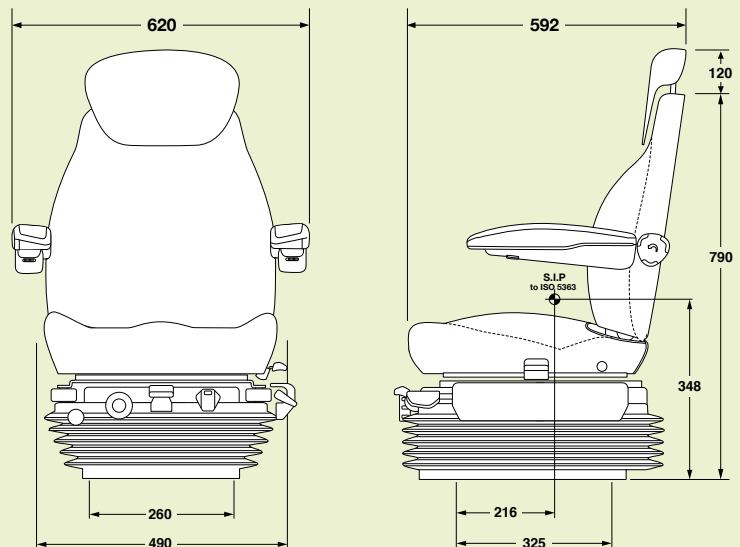



# 81/E6



**Suspension Type:** Mechanical 81

**Upper Type:** E6 low back

**Belt Type:** 2" optional

**Suspension Stroke:** 175mm

**Height Adjust:** Vertical 75mm integral

**Weight Range:** 50 - 120kg

**Vehicle Categories:** EEC type approved classes I/II/III

**Alternative:** E1 mid back option

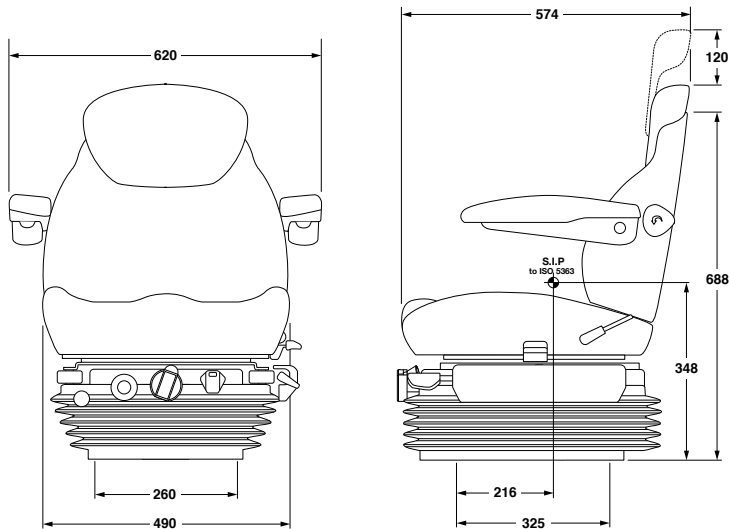

# AIR 15/E6



**Suspension Type:** Air 15

**Upper Type:** E6 low back

**Belt Type:** 2" optional

**Suspension Stroke:** 150mm

**Height Adjust:** Vertical 70mm integral

**Weight Range:** 50 - 120kg

**Vehicle Categories:** EEC type approval classes I/II/III

**Air Control:** 12v integral compressor

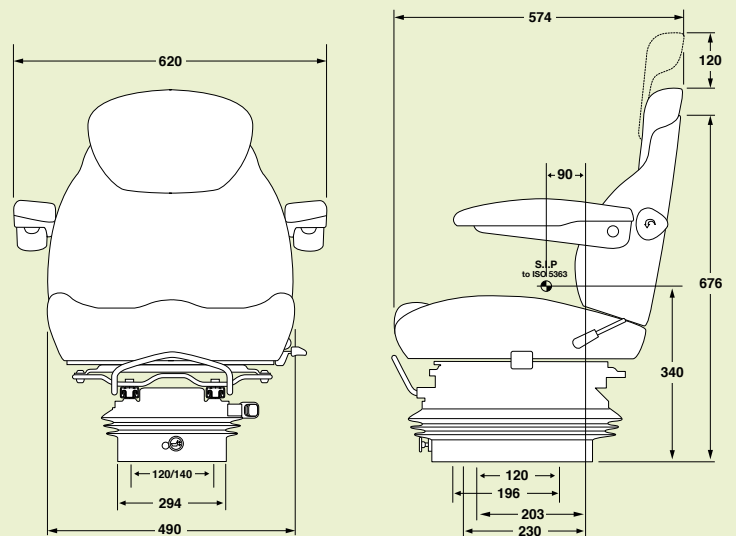

85/K6

INVICTUS *air*

NEW FOR JULY 2011

LB DELUXE



15/K6

INVICTUS *air*

NEW FOR JULY 2011

LB DELUXE



**Suspension Type:** Air 85

**Upper Type:** K6 low back

**Belt Type:** Optional 2" recoil type

**Suspension Stroke:** 175mm

**Height Adjust:** Vertical 75mm integral

**Weight Range:** 50 - 120kg

**Vehicle Categories:** EEC Type approved classes I/II/III

**Air Control:** 12v integral compressor

**Special optional features:** - Electrically powered air lumbar  
- Air ventilation for heating and cooling  
- Seat cushion length and tilt adjustment (50mm)

**Suspension Type:** Air 15

**Upper Type:** K6 - low back

**Belt Type:** Optional 2" recoil type

**Suspension Stroke:** 150mm (110 and 80 options)

**Height Adjust:** Vertical 70mm integral

**Weight Range:** 50 - 120kg

**Vehicle Categories:** EEC type approval classes I/II/III

**Air Control:** 12v integral compressor

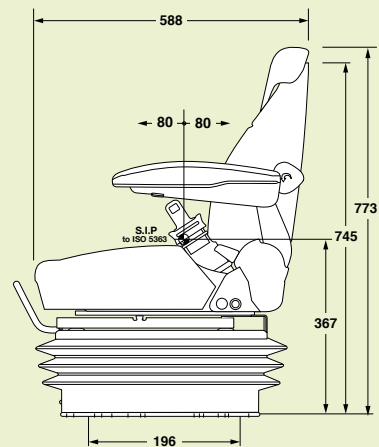
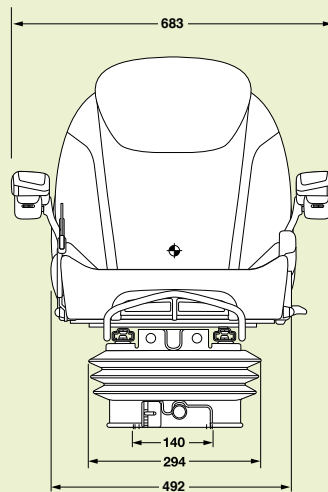
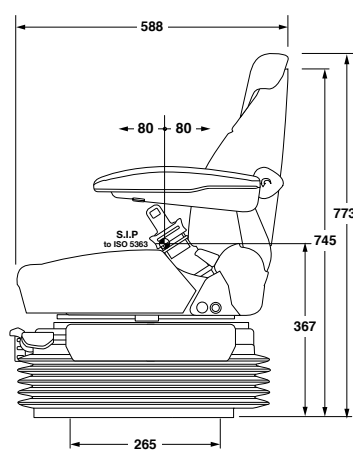
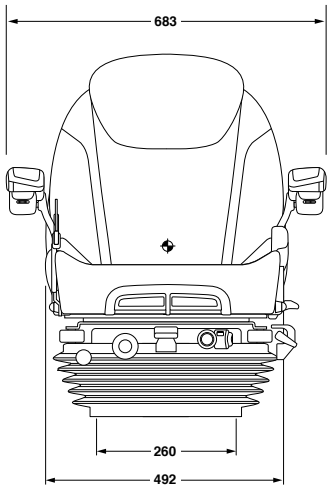

# 81/K1



**Suspension Type:** Mechanical 81

**Upper Type:** K1 mid back

**Belt Type:** 2" optional

**Suspension Stroke:** 175mm

**Height Adjust:** Vertical 75mm integral

**Weight Range:** 50 - 120kg

**Vehicle Categories:** EEC type approval classes I/II/III and telescopic handlers

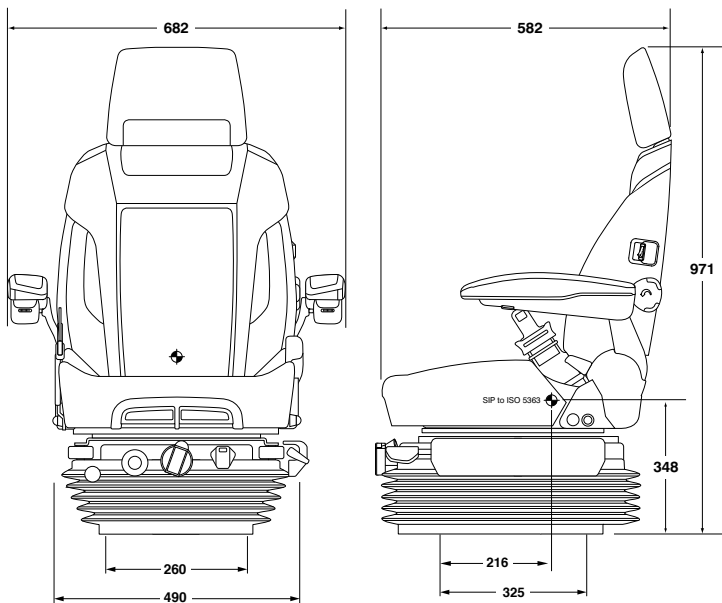

# 11/K1



**Suspension Type:** Mechanical 11

**Upper Type:** K1 mid back

**Belt Type:** 2" optional

**Suspension Stroke:** 80 - 150mm

**Height Adjust:** Vertical 70mm integral

**Weight Range:** 50 - 120kg

**Vehicle Categories:** EEC type approval classes I/II/III and telescopic handlers

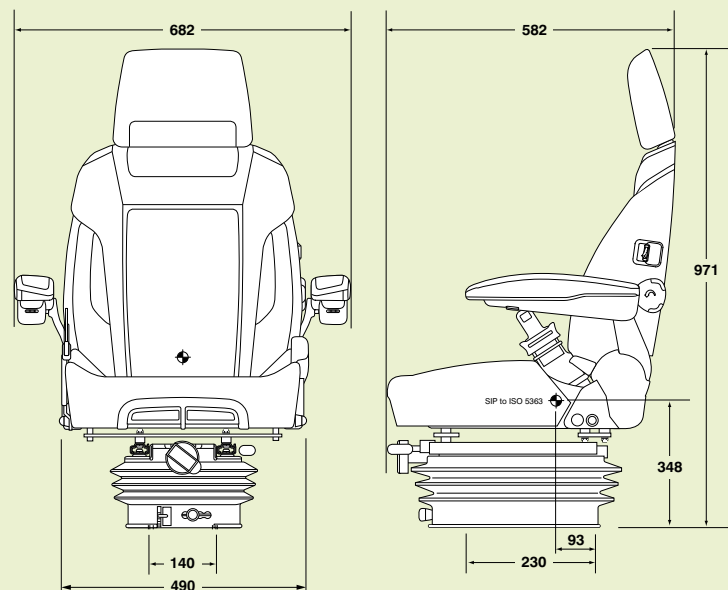



# AIR 15/P6



# 11/P6



**Suspension Type:** Air 15

**Upper Type:** P6 pan - low back

**Belt Type:** Optional 2" recoil type

**Suspension Stroke:** 150mm (110 and 80 options)

**Height Adjust:** Vertical 70mm integral

**Weight Range:** 50 - 120kg

**Vehicle Categories:** EEC type approval classes I/II/III

**Air Control:** 12v integral compressor

**Suspension Type:** Mechanical 11

**Upper Type:** P6 pan - low back

**Belt Type:** Optional 2" recoil type

**Suspension Stroke:** 80-150mm

**Height Adjust:** Vertical 70mm integral

**Weight Range:** 50 - 120kg

**Vehicle Categories:** EEC type approval classes I/II/III

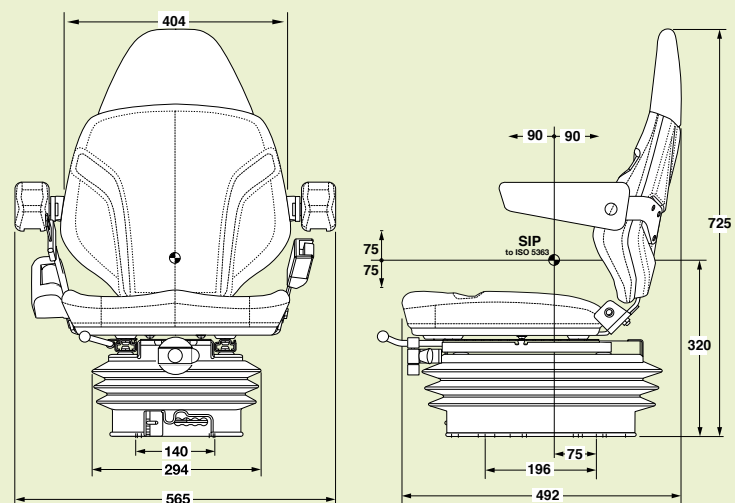
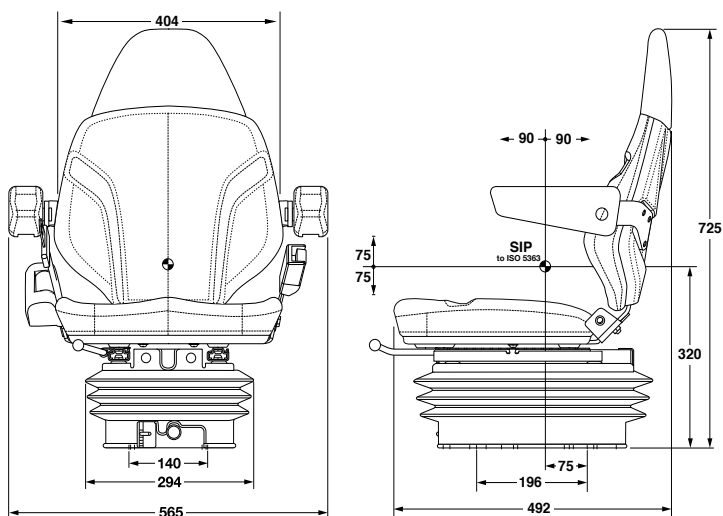

## AIR 15/U4 AIRMASTER



**Suspension Type:** Air 15

**Upper Type:** U4 low back

**Belt Type:** Optional 2" recoil type

**Suspension Stroke:** 150mm (110 and 80 options)

**Height Adjust:** Vertical 70mm integral

**Weight Range:** 50 - 120kg

**Vehicle Categories:** EEC type approval classes I/II/III

**Air Control:** 12v integral compressor

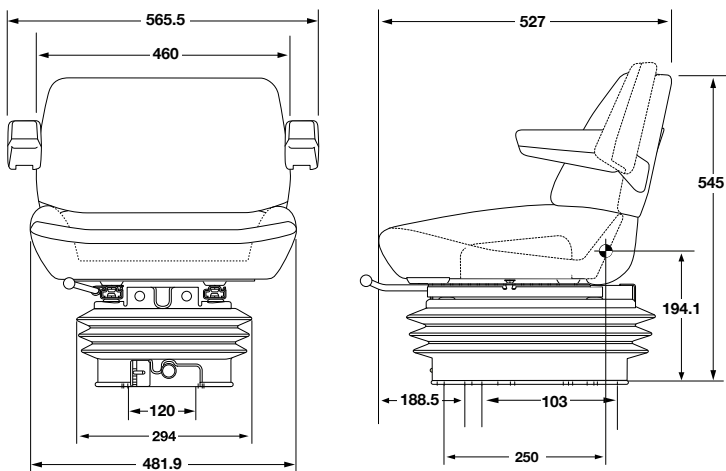

## XH2/U4 FIELDMASTER



**Suspension Type:** Mechanical XH2

**Upper Type:** U4 low back

**Belt Type:** Optional 2" recoil type

**Suspension Stroke:** 90-160mm

**Height Adjust:** Vertical 70mm integral

**Weight Range:** 50 - 120kg

**Vehicle Categories:** EEC type approval classes I/II/III

**Special optional feature:** 20°/20° swivel and 0-180° turntable

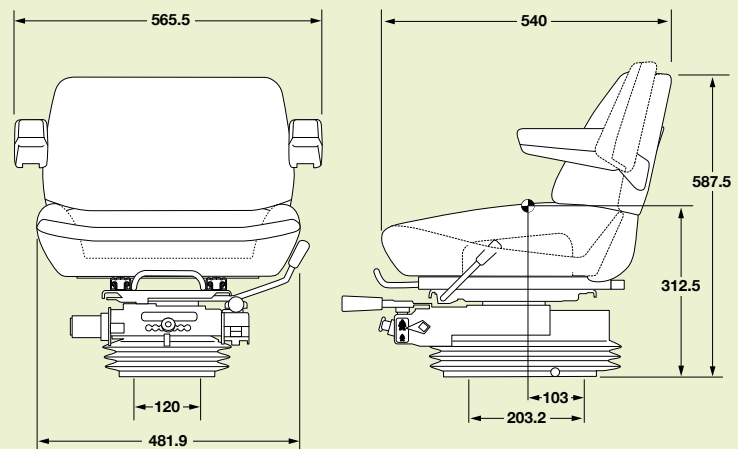



11/E6



**Suspension Type:** Mechanical 11

**Upper Type:** E6 low back

**Belt Type:** Optional 2" recoil type

**Suspension Stroke:** 80-150mm

**Height Adjust:** Vertical 70mm integral

**Weight Range:** 50 - 120kg

**Vehicle Categories:** EEC type approval classes I/II/III

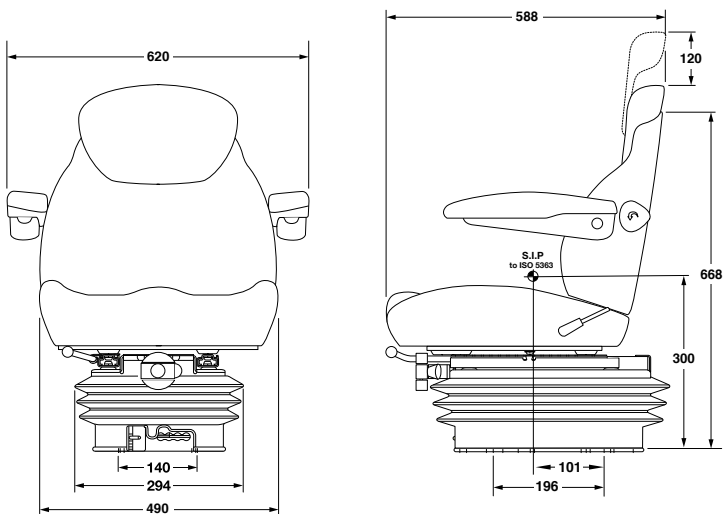

XL2/U1 KABMASTER



**Suspension Type:** Mechanical XL2

**Upper Type:** U1 low back

**Belt Type:** Optional 2" recoil type

**Suspension Stroke:** 100mm

**Height Adjust:** N/A

**Weight Range:** 50 - 120kg

**Vehicle Categories:** Small tractors (aftermarket only)

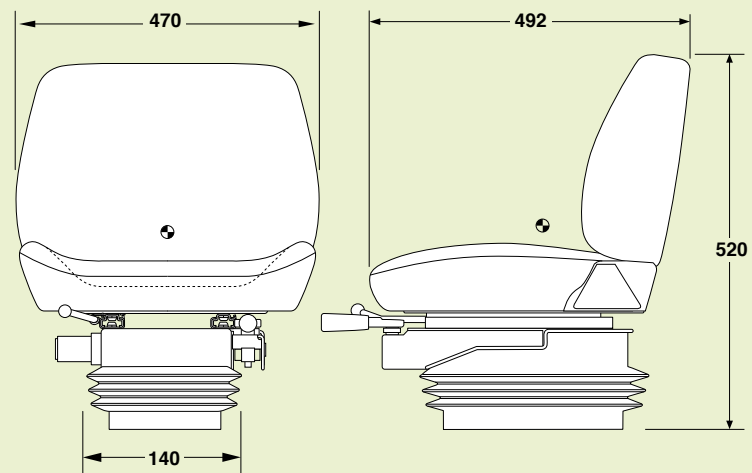

## XH2/P2



**Suspension Type:** Mechanical XH2

**Upper Type:** P2 low back

**Belt Type:** Optional 2" recoil type

**Suspension Stroke:** 90-160mm

**Height Adjust:** Vertical 70mm integral

**Weight Range:** 50 - 120kg

**Vehicle Categories:** EEC type approval classes I/II/III

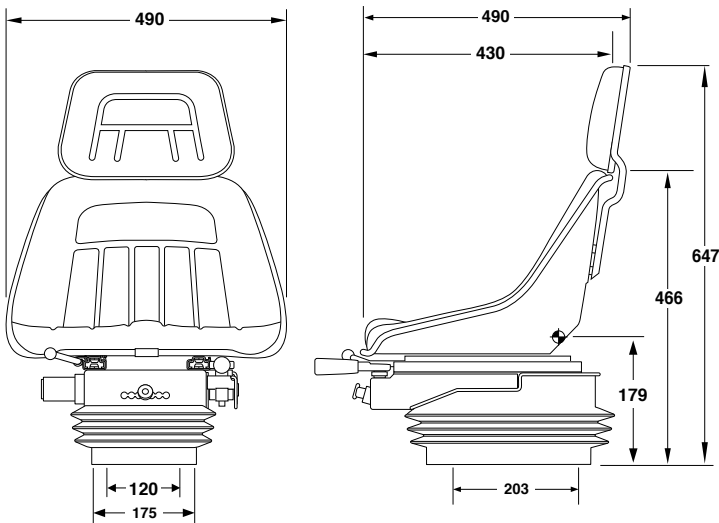

## XH2/P1



**Suspension Type:** Mechanical XH2

**Upper Type:** P1 low back

**Belt Type:** Optional 2" recoil type

**Suspension Stroke:** 90-160mm

**Height Adjust:** Vertical 70mm integral

**Weight Range:** 50 - 120kg

**Vehicle Categories:** EEC type approval classes I/II/III

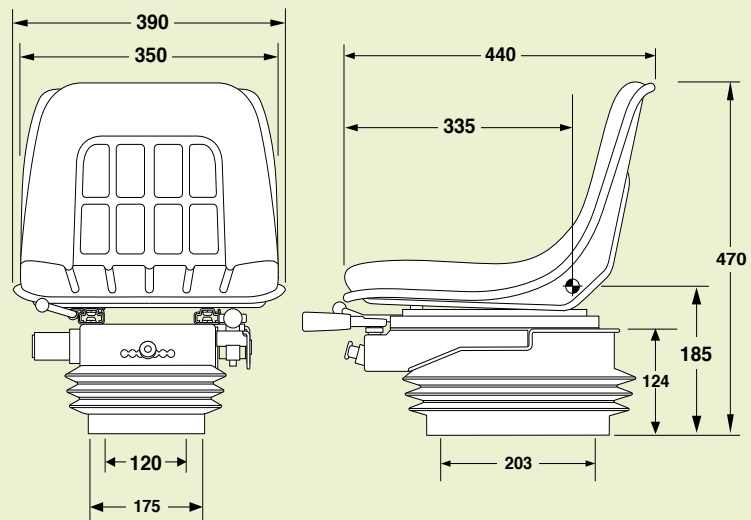



# Air Compact



- Suspension Type:** Air or Mechanical Compact
- Upper Type:** Integral compact - low back
- Belt Type:** Optional 2" recoil type
- Suspension Stroke:** 60mm (40 and 80mm options)
- Height Adjust:** N/A
- Weight Range:** 50 - 150kg Air (50 - 140kg Mechanical)
- Vehicle Categories:** IT1, IT2, EM6, EM7, EM8, EM9 and ride on mowers
- Air Control:** 12v integral compressor
- Special features:** Operator sensor in seat cushion and demountable backrest

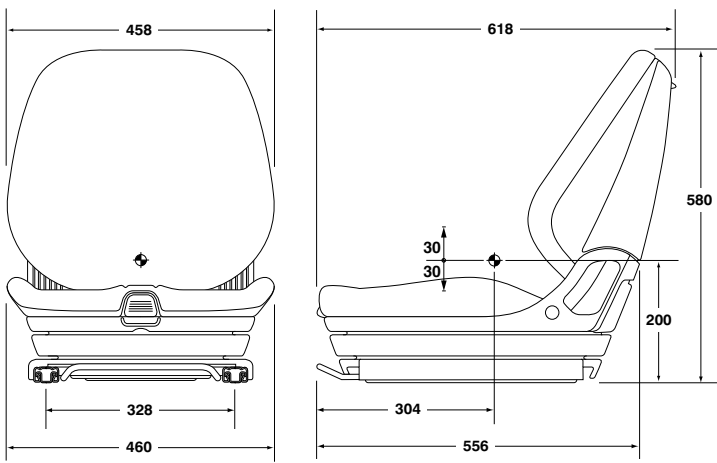

AIR COMPACT SHOWN



# RANGE FEATURES



**Weight Adjuster**  
(XL2/XH2)



**Weight Adjuster**  
(800/100)



**Height Adjuster**  
(XH2)



**Fore and aft Isolator**  
(800)



**Mechanical Lumbar**



**Slide Rail Adjuster**  
(KAB type)



**Seat Belts**



**Recliner**



**Air Valve**  
(85)



**One Touch Riser (OTR)**  
(800 Air)



**Ride Indicator**  
(80)



**Variable upstop**  
(800)

85/K6 **INVICTUS air**



**NEW  
FOR JULY  
2011**

## Operator Comfort and safety at the push of a button

*Stylish, strong solution for farmers using medium or large tractors and combine harvesters*

### FEATURES

- ▶ Low frequency air suspension seat with OTR for one touch mid suspension positioning
- ▶ NEW Air ventilation option for heating and cooling
- ▶ NEW Electrically powered air lumbar
- ▶ NEW seat cushion length and tilt adjustment feature
- ▶ Fore and aft isolator



Heater and Ventilation Control

Electric Lumbar Support

Recline adjuster

Swivel Control

Fore and aft isolator

Cushion length adjustment

Cushion tilt adjustment

Stroke limiter

Height adjuster

OTR

### Health and Safety

It is important that drivers of work vehicles are fully protected from harmful vibrations. KAB seats can eliminate up to 70% of these. Careful seat selection is important and through consultation with KAB Seating's network of Authorised distributors the appropriate seat choice can be made to fit most popular brands.

### Installation

Care should be taken to ensure a correct installation is made and the seat suspension movements and adjustments are free from obstructions in the cab area.

### Maintenance

KAB Seating provides a full range of service parts to ensure seats can be maintained properly, key wear items such as shock absorbers, seat cushions and air valves should be replaced on a regular basis in accordance with the type of usage, amount of usage and environmental factors.

Regular removal of dust and dirt from the seat and cabin will improve the longevity of the seat.

**KAB UK - Kab Seating Ltd** - Northampton  
Tel: +44 (0) 1604 641522 E.mail: infouk@cvgrp.com  
www.kabseating.com

**KAB Sweden - Kab Seating AB** - Stockholm  
Tel: +46 (0) 8 554 427 00 E.mail: infoSweden@cvgrp.com

**KAB Belgium - Kab Seating SA** - Seneffe  
Tel: +32 (0) 64 27 34 70 E.mail: infoBelgium@cvgrp.com

**KAB France - Sales Office** - Chatillon, Paris  
Tel: +33 (0) 1 40 92 97 40 E.mail: infoFrance@cvgrp.com

**KAB Australia - Kab Seating Pty. Ltd** - Brisbane  
Tel: +61 (0) 7 3344 0500 E.mail: infoAustralia@cvgrp.com

**CVG China - CVG Vehicle Components** - Shanghai  
Tel: +86 21 5958 5801 E.mail: infoChina@cvgrp.com

**CVG World Headquarters** - New Albany, Ohio, USA  
Tel: (614) 289-5360 E.mail: info@cvgrp.com  
www.cvgrp.com

**CVG National Seating USA** - Vonore, Tennessee  
Tel: +1 800 354 9621 E.mail: infoAmerica@cvgrp.com

Distributor